

GRAIN
STORAGE &
HANDLING
SYSTEMS





Alapala



STORAGE SYSTEM

WIDER RANGE & CUSTOMIZED SOLUTIONS

Alapala storage systems can be customized to your requirements and operations including features such as special discharge outlets, longer hopper legs and reinforced designs for higher catwalk support loads, there is an Alapala solution available.



FLAT SILOS WITH CAPACITY FROM
 102 m^3 TO 20.923 m^3



HOPPER SILOS WITH
CONES OF 45° & 60°



TRUCK LOADING SILOS



SQUARE SILOS

**HIGH QUALITY STEEL,
LONG SERVICE LIFE AND
COMPUTERIZED DESIGN**

Choosing the right grain storage system for your operation demands depends not only on a careful analysis for both your short and long term needs, with appropriate solutions for the many factors that affect the overall product quality and functionality. As Alapala we are proud of having provided grain storage products that are considered among the most innovative on the market today. Our commercial flat bottom and grain bins with hoppers which represent the latest technology in grain storage. The efficient stiffener design can handle the draw down of the silos where severe seismic loads are required. This stiffening system can also be adapted to meet different load requirements of specific installations. Finally, our grain bins and hopper silos are made by using lead free senzimir galvanized coating on the wall sheets.

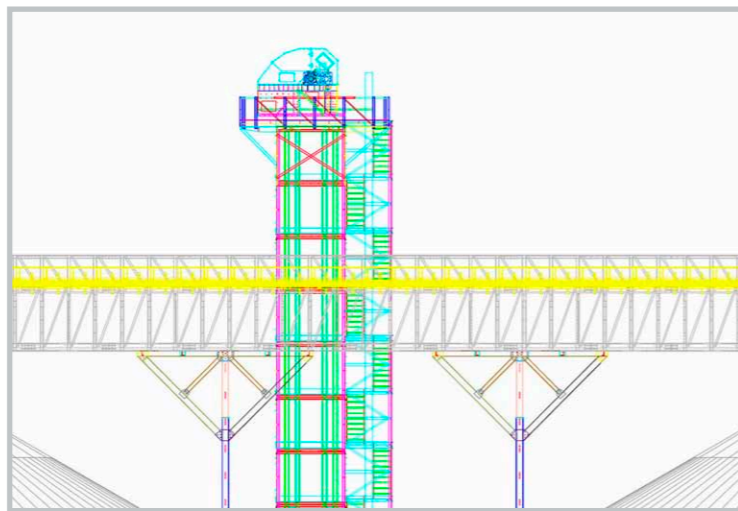

METALLIC SILOS The design of silos has been performed according to international standards EUROCODE 1-4 and ANSI, and according to the provisions of the actual European Parliament and European Directive (CE)

ROOF The silos incorporate pitched roofs at 30° to suit the slope of grain and optimize their storage capacity. Roof structure offers optimal strength to high loads, providing durability under heavy snow, ice and other extreme weather conditions.

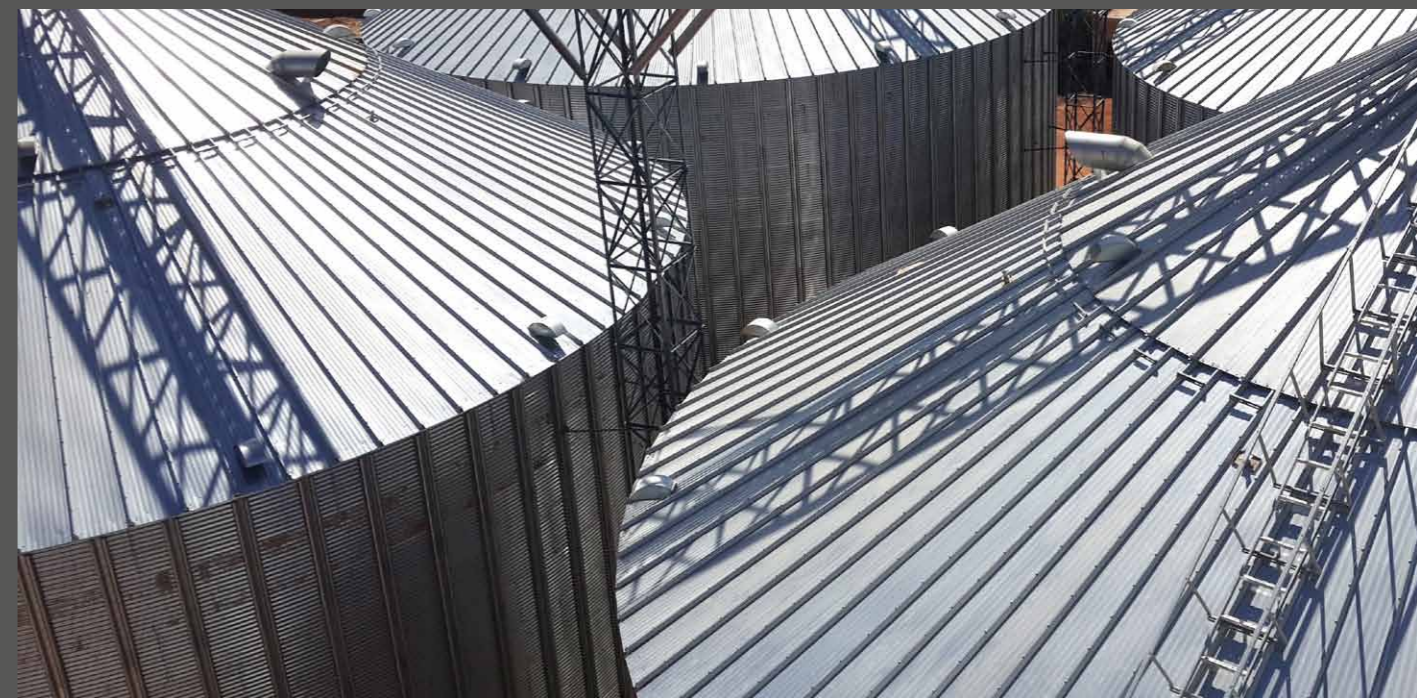

CYLINDER Consisting of corrugated steel panels 600 g/m² in variable thicknesses from 1 to 4 mm. The panels are reinforced with exterior vertical stiffeners in omegashaped, made of galvanized steel with different thicknesses and variable resistance.

HOPPER The hopper is constituted by metal sections joined together, forming a metallic cone 45° or 60°. The hopper is elevated by a metallic structure formed by laminated profiles connected by braces.

Zinc-plated covering bolting M8, M10 and M12, quality 5-6-8-8 with flat, concave and rubber washers. Sealing of bolting lines by mastic BOSTIK type for a perfect watertightness.

GRAIN HANDLING



OUR PRODUCT RANGE INCLUDES:

- Belt conveyors
- Bucket elevators
- Chain conveyors
- Accessories



➤ BELT CONVEYOR

UP TO 1.500 Tn./h.

- Thirty models divided in four different series to offer each user the most suitable solution as far as capacity, technical characteristics and type of use.
- The surface treatments may be hot-dip galvanization and epoxy painting.



➤ BELT CONVEYOR

UP TO 1.500 Tn./h.

GENERAL CHARACTERISTICS

- Design for the transport of granular or dusty products (typically cereals, oilseeds, flour, meals and their by-products).
- Wide range of machines. Customization according to the customer's requirements.
- Surface treatment by hot-dip galvanization or epoxidic dust painting (also for human food).
- Standard execution (CE) or in compliance with ATEX Directive 94/9/CE (Z=22).

Drive head

- Drive unit direct coupled to the shaft. **(1)**
- Drive head with motor, reducer and joints, complete with support. **(2)**
- Standard drive head (no end outlet) direct coupled to the shaft. **(3)**
- Standard drive head (no end outlet) with motor, reducer and joints, complete with support.
- Anti-clogging system at the discharging hopper.
- Belt alignment control system. **(4)**
- Rubber coated pulley.

Tail

- Standard tensioning system by screws. **(5)**
- Tail with belt tensioning system by standard counterweight. **(6)**
- Special tail for belt tensioning system with tower counterweight. **(7)**
- Special execution for reversible machine.
- Smooth pulley.
- Speed monitoring system. **(8)**
- Belt alignment control system. **(9)**

Belts

- Different type of belt: anti-abrasive, oil resistant, flame retardant, food quality.

Upright Supports

- Standard Upright Supports. **(10)**

Accessories

- Travelling tripper (1 or 2 ways outlet). **(11)**
- End outlet hopper.
- Stationary feeding hopper.
- Travelling feeding hopper.
- Travelling hopper, jetty installation.
- Adjustable supports.
- Standard covering. **(12)**
- Covering for jetty installation. **(13)**
- Emergency stop system.
- Counterweight. **(14)**
- Tensioning Tower. **(15)**

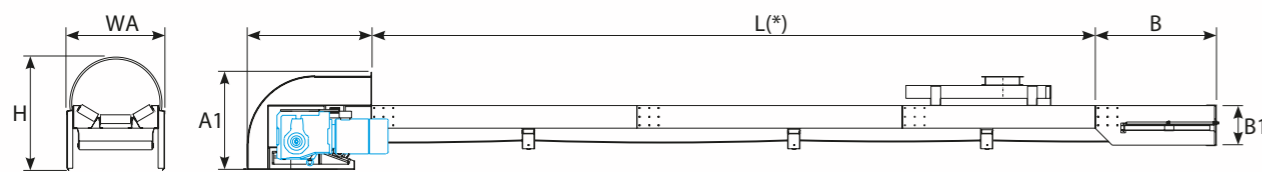
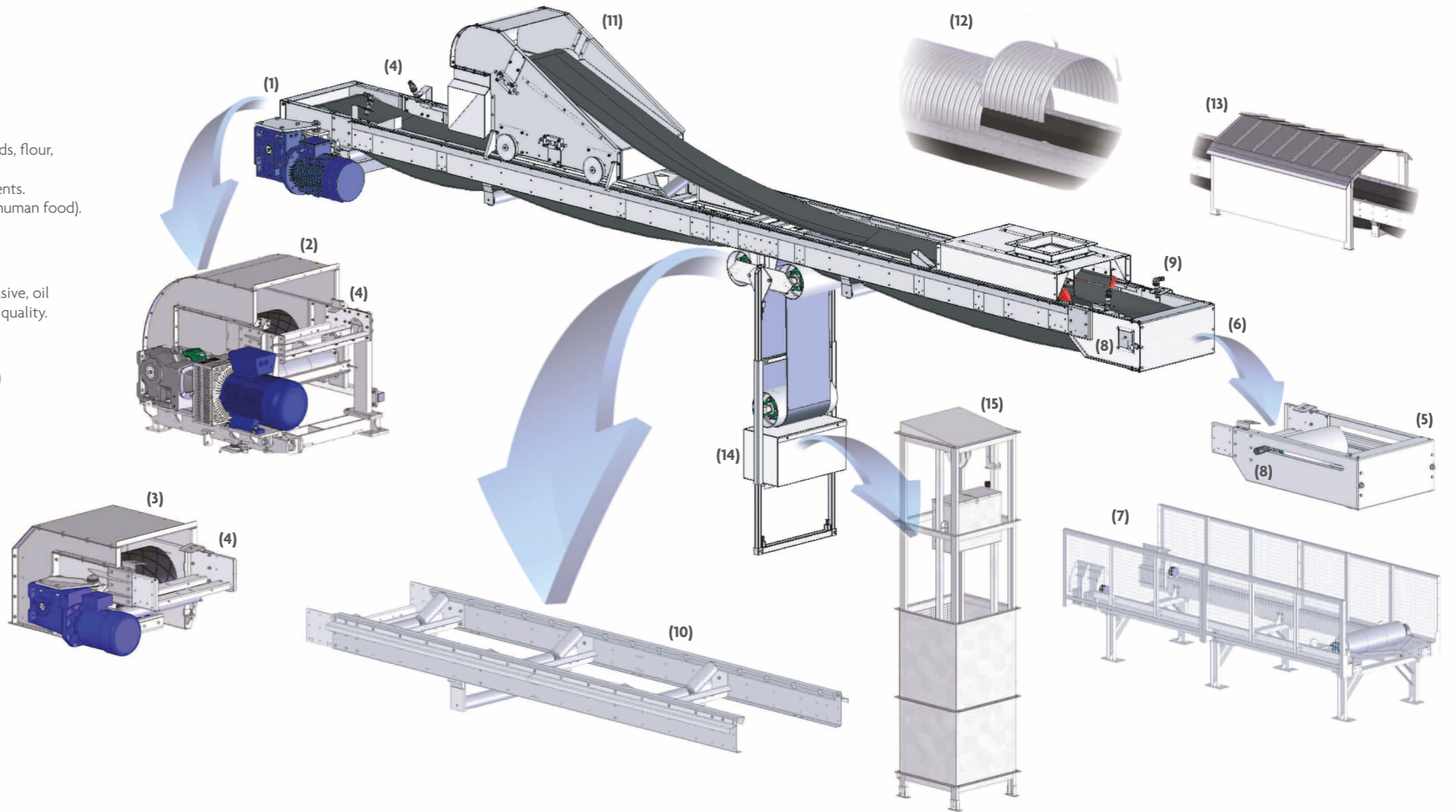

		TNM.300.340	TNM.350.340	TNM.450.340
Capacity ⁽¹⁾	t/h		40 ÷ 120	
Capacity ⁽¹⁾	bph		1455 ÷ 4366	
Max Power	kW		11	
Max Length	m		-	
Screw Tensioning System up to	m		30	
Dimensions: W / H	mm	525 / 680	615 / 680	710 / 715
Dimensions: A / A1	mm		970 / 540	
Dimensions: B / B1	mm		1000 / 300	
Head Thickness ⁽²⁾	mm		3,0 - 3,0	
Tail Thickness ⁽²⁾	mm		3,0 - 3,0	
Upright Supports Thickness ⁽²⁾	mm		2,0 - 5,0	
Design Working Load ⁽⁵⁾	h/y		5000	

(1) Capacities are referred to dry cereal (r.h. 14%), with bulk density 0,78 t/m³ and impurities lower than 4%

(2) Head Thickness: Flanks - Hood
(2) Tail Thickness: Flanks - Back Cover
(2) Upright Supports Thickness: Frame - Spacer

(5) Design working load has been considered for dry cereal (r.h. 14%), with bulk density 0,78 kg/m³ and impurities lower than 4%

(*) L = 992 / 1736 / 1984 / 2480 / 2976 mm (TNM.xxx.340) - L = 1000 / 2000 / 2500 / 2750 mm (TNM.xxx.240, TNM.xxx.500) - L = 1984 / 2480 / 2976 mm (TNM.xxx.630) (Special dimensions available upon request)

TNM.240.600	TNM.240.650	TNM.240.750	TNM.500.600	TNM.500.650	TNM.500.750	TNM.630.1000	TNM.630.1200
150 ÷ 350			150 ÷ 350			500 ÷ 1200	
5457 ÷ 12734			5457 ÷ 12734			18191 ÷ 43658	
11			45			132	
30			-			-	
30			30			30	
955 / 1130	1020 / 1170	1105 / 1190	955 / 1130	1020 / 1170	1105 / 1190	1530 / 1780	1740 / 1780
1090 / 695			1330 / 1010			2030 / 1170	
1750 / 430			1750 / 430			1300 / 560	
3,0 - 3,0			3,0 - 3,0			5,0 - 4,0	
3,0 - 3,0			3,0 - 3,0			5,0 - 5,0	
3,0 - 5,0			3,0 - 5,0			5,0 - 5,0	
5000			5000			5000	

(1) Capacities are referred to dry cereal (r.h. 14%), with bulk density 0,78 t/m³ and impurities lower than 4%

(2) Head Thickness: Flanks - Hood

(2) Tail Thickness: Flanks - Back Cover

(2) Upright Supports Thickness: Frame - Spacer

(5) Design working load has been considered for dry cereal (r.h. 14%), with bulk density 0,78 kg/m³ and impurities lower than 4%

(*) L = 992 / 1736 / 1984 / 2480 / 2976 mm (TNM.xxx.340) - L = 1000 / 2000 / 2500 / 2750 mm (TNM.xxx.240, TNM.xxx.500) - L = 1984 / 2480 / 2976 mm (TNM.xxx.630) (Special dimensions available upon request)

➤ BUCKET ELEVATORS

GENERAL CHARACTERISTICS

- Design for the vertical transport of cereals, in large farms and grain stores plants.
- Base structure in pre-galvanized steel DX51D Z 275 UNI EN 10327.
- Standard execution (CE) or in compliance with ATEX Directive 94/9/CE (Z=22).

Drive head

- Drive unit direct coupled to the shaft. **(1)**
- Anti-clogging system at the discharging hopper. **(2)**
- Belt alignment control system. **(3)**
- Smooth pulley.
- Upper cover dismountable.
- Set of anti-wearing sheets interchangeable, in special steel.

Tail

- Smooth cage pulley.
- Standard tensioning system by screws. **(4)**
- Speed monitoring system.
- Belt alignment control system. **(3)**

Buckets and Belts

- Buckets for granular products in pressed steel.
- Different type of belt: anti-abrasive, oil resistant, flame retardant.

Legs

- Standard leg. **(5)**
- Inspection leg. **(6)**

Accessories

- Extra inlet hopper. **(7)**
- Hopper for product recovering. **(8)**
- Discharging hopper with square or round outlet.
- Explosion venting panel on casing. **(9)**
- Aspiration connection on casing. **(10)**

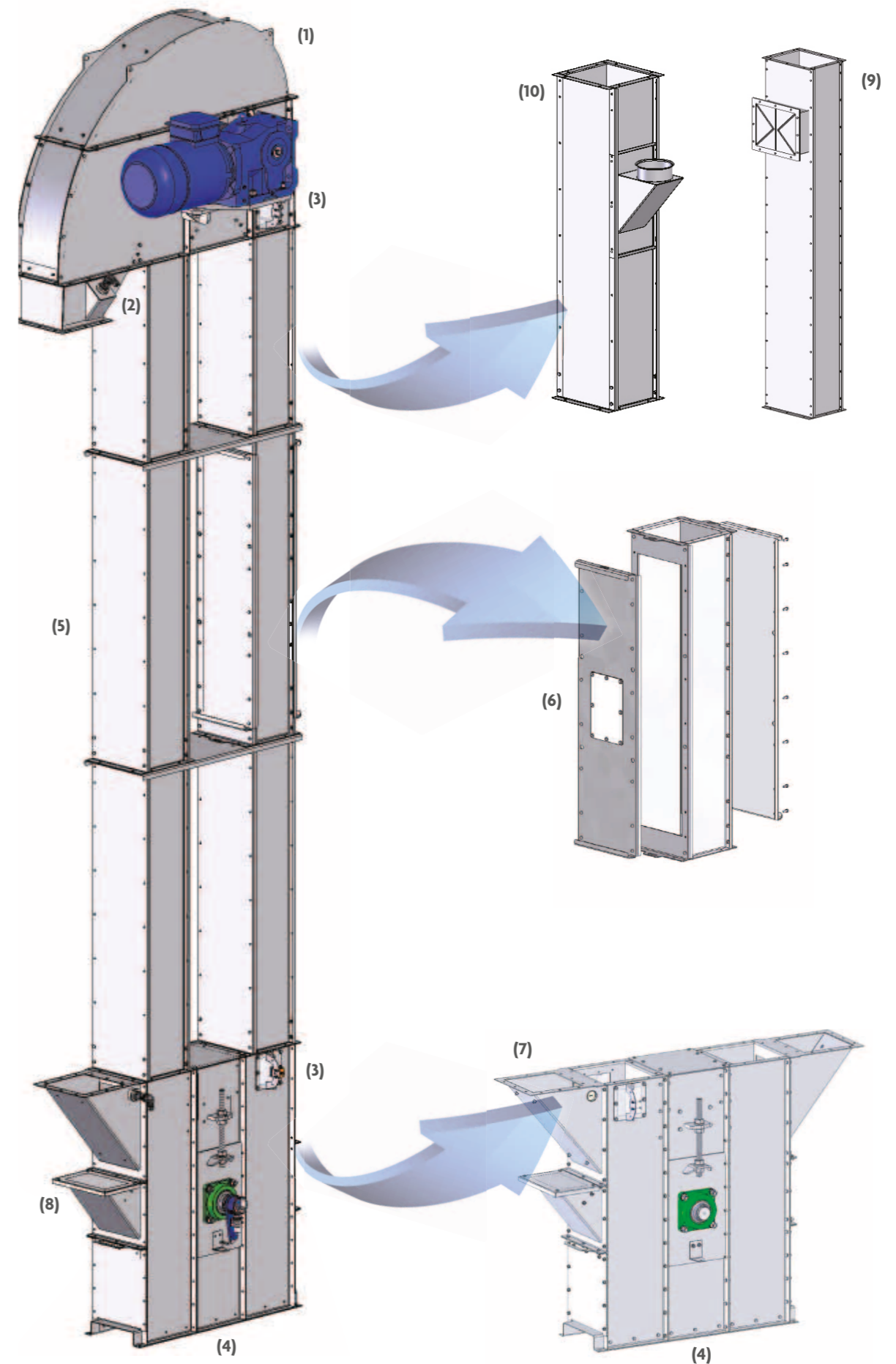
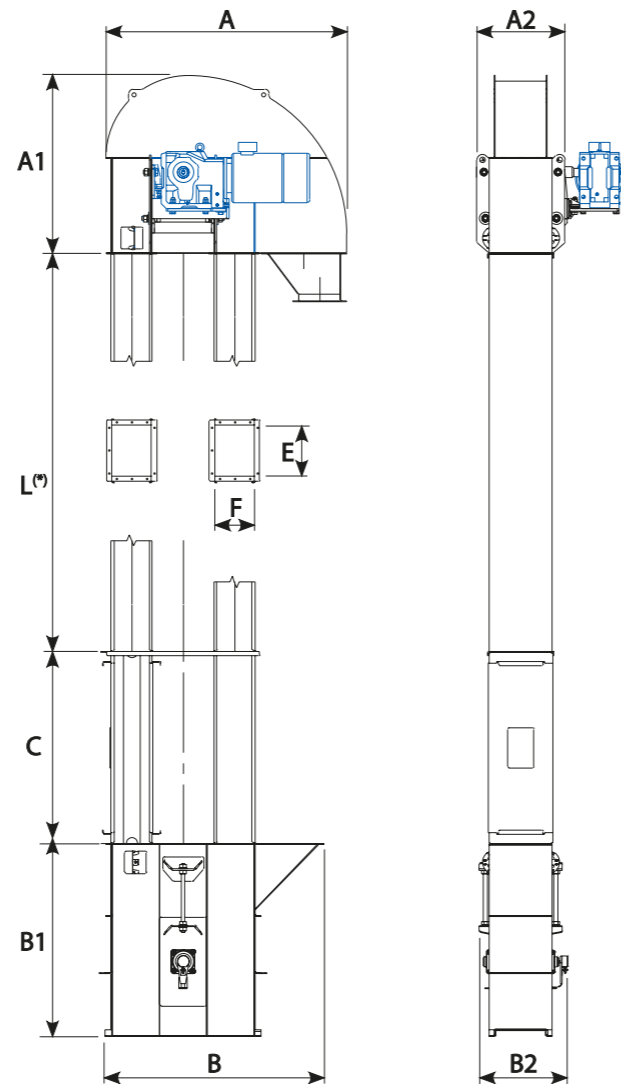

		ELA.470	ELA.550
Capacity ⁽¹⁾	t/h	525 / 680	615 / 680
Capacity ⁽¹⁾	bph	525 / 680	615 / 680
Max Power	kW	525 / 680	615 / 680
Self-standing machine up to	m	525 / 680	615 / 680
Dimensions: A / A1 / A2	mm	525 / 680	615 / 680
Dimensions: B / B1 / B2	mm	525 / 680	615 / 680
Dimensions: C / E / F	mm	525 / 680	615 / 680
Head Thickness ⁽²⁾	mm	525 / 680	615 / 680
Tail Thickness ⁽³⁾	mm	525 / 680	615 / 680
Legs Thickness ⁽⁴⁾	mm	525 / 680	615 / 680
Anti-Wearing Steel Thickness	mm	525 / 680	615 / 680
Design Working Load ⁽⁵⁾	h/y	525 / 680	615 / 680

- (1)** Capacities are referred to dry cereal (r.h. 14%), with bulk density 0,78 t/m³ and impurities lower than 4%
- (2)** Head Thickness: Flanks-Cover
- (3)** Tail Thickness: Flanks-Belt Tensioning Slides
- (4)** Legs made by bolted panels
- (5)** Design working load has been considered for dry cereal (r.h. 14%), with bulk density 0,78 t/m³ and impurities lower than 4%
- (*)** L = 2900 / 2400 / 1900 / 1400 / 900 / 400 mm (Special dimensions available upon request)

➤ BUCKET ELEVATORS

GENERAL CHARACTERISTICS

- Design for the vertical transport of granular or dusty products (typically cereals, oilseeds, flour, meals and their by-products).
- Wide range of machines. Customization according to the customer's requirements.
- Structure with high resistance to over pressure ($\geq 2,0$ bar).
- Surface treatment by hot dip galvanization or epoxidic dust painting (also for human food).
- Standard execution (CE) or in compliance with ATEX Directive 94/9/CE (Z=22).

Drive head

- Drive unit direct coupled to the shaft. **(1)**
- Drive head with motor, reducer and joints, complete with support. **(2)**
- Anti-clogging system at the discharging hopper. **(3)**
- Belt alignment control system.
- Smooth or rubber coated pulley.
- Upper cover dismantlable (one or two pieces).
- Set of anti-wearing sheets interchangeable, in special steel or Rhinohyde.
- Kit for explosion suppression system. **(4)**

Tail

- Smooth or squirrel cage pulley.
- Standard tensioning system by screws. **(5)**
- Tensioning system by counterweight. **(6)**
- Dust tight tail (for application with dusty products).
- Self-cleaning tail. **(7)**
- Speed monitoring system.
- Belt alignment control system.
- Sensor for explosion suppression system.

Legs

- Standard legs. **(8)**
- Inspection legs. **(9)**

Buckets and Belts

- Buckets for granular products.
- Buckets for dusty products.
- Buckets in pressed steel or in plastic material: polyethylene, polyamide, polyurethane.
- Different type of belt: anti-abrasive, oil resistant, flame retardant, food quality.

Accessories

- Extra inlet hopper. **(10)**
- Hopper for product recovering. **(11)**
- Discharging hopper with square outlet. **(12)**
- Over pressure discharge system with chimney. **(13)**
- Explosion venting panel on head. **(14)**
- Explosion venting panel on casing. **(15)**
- Aspiration connection on casing. **(16)**

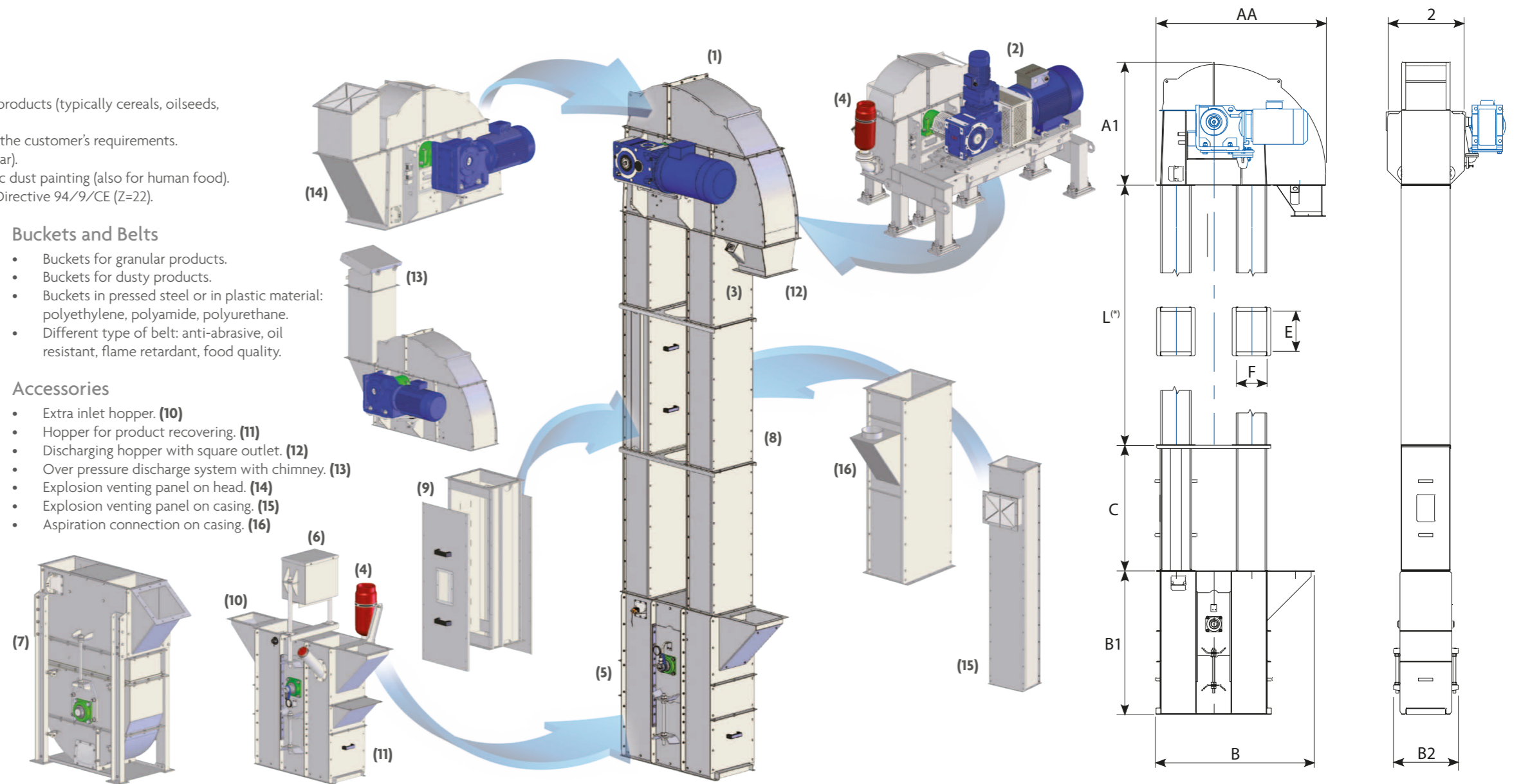

		ETM.300	ETM.400	ETM.500
Capacity ⁽¹⁾	t/h	20 + 35	25 + 100	60 + 175
Capacity ⁽¹⁾	bph	723 + 1273	910 + 3638	2183 + 6367
Max Power	kW	7,5	11	45
Self-standing machine up to	m	25	35	40
Dimensions: A / A1 / A2	mm	933 / 647 / 345	1326 / 1038 / 476	1509 / 1059 / 693
Dimensions: B / B1 / B2	mm	827 / 715 / 383	1170 / 1000 / 440	1425 / 1250 / 535
Dimensions: C / E / F	mm	1400 / 165 / 145	1400 / 250 / 230	1400 / 335 / 269
Head Thickness ⁽²⁾	mm	3,0 - 3,0	3,0 - 3,0	4,0 - 3,0
Tail Thickness ⁽³⁾	mm	3,0 - 6,0	3,0 - 6,0	4,0 - 8,0
Legs Thickness ⁽⁴⁾	mm	2,0	2,0	2,0
Anti-wearing Steel Thickness	mm	4,0	4,0	4,0
Design Working Load ⁽⁵⁾	h/y	5000	5000	5000

- (1)** Capacities are referred to dry cereal (r.h. 14%), with bulk density 0,78 t/m³ and impurities lower than 4%
- (2)** Head Thickness: Flanks-Cover
- (3)** Tail Thickness: Flanks-Belt Tensioning Slides
- (4)** Legs made by bolted panels
- (5)** Design working load has been considered for dry cereal (r.h. 14%), with bulk density 0,78 t/m³ and impurities lower than 4%
- (*)** L = 2900 / 2400 / 1900 / 1400 / 900 / 400 mm (Special dimensions available upon request)

	ETM.630	ETM.800	ETM.1000	ETM.1200
Capacity ⁽¹⁾	100 + 250	150 + 350	350 + 650	400 + 1200
Capacity ⁽¹⁾	3638 + 9095	5457 + 12734	12734 + 23648	14553 + 43658
Max Power	75	110	160	250
Self-standing machine up to	48	50	50	50
Dimensions: A / A1 / A2	1880 / 1364 / 860	2190 / 1594 / 970	2377 / 1896 / 1454	2589 / 2279 / 1918
Dimensions: B / B1 / B2	1767 / 1600 / 775	2075 / 1905 / 799	2305 / 2000 / 1310	2562 / 2150 / 1656
Dimensions: C / E / F	1400 / 450 / 340	2000 / 500 / 350	1400 / 250 / 230	1400 / 335 / 269
Head Thickness ⁽²⁾	4,0 - 4,0	5,0 - 4,0	5,0 - 5,0	5,0 - 5,0
Tail Thickness ⁽³⁾	5,0 - 10,0	5,0 - 15,0	6,0 - 15,0	6,0 - 15,0
Legs Thickness ⁽⁴⁾	3,0	3,0	3,0	3,0
Anti-wearing Steel Thickness	4,0	4,0	4,0	4,0
Design Working Load ⁽⁵⁾	5000	5000	5000	5000

- (1)** Capacities are referred to dry cereal (r.h. 14%), with bulk density 0,78 t/m³ and impurities lower than 4%
- (2)** Head Thickness: Flanks-Cover
- (3)** Tail Thickness: Flanks-Belt Tensioning Slides
- (4)** Legs made by bolted panels
- (5)** Design working load has been considered for dry cereal (r.h. 14%), with bulk density 0,78 t/m³ and impurities lower than 4%
- (*)** L = 2900 / 2400 / 1900 / 1400 / 900 / 400 mm (Special dimensions available upon request)

CHAIN CONVEYOR

GENERAL CHARACTERISTICS

- Design for conveying cereals, in large farms and grain stores plants.
- Base structure in pre-galvanized steel DX51D Z 275 UNI EN 10327;
- Standard execution (CE) or in compliance with ATEX Directive 94/9/CE (Z=22).

Drive head

- Drive unit direct coupled to the shaft. **(1)**
- Anti-clogging sensor and inspection window.

Tail

- Tensioning system by screws. **(2)**
- Tensioning slides with self-aligning bearings.
- Speed monitoring system. **(3)**
- Special execution for reversible machine.

Conveying chain

- Belt-link scraper chain. **(4)**
- PE-UHMW scrapers.
- Recovery buckets.

Casings

- Standard casings. **(5)**
- Side-inlet casings (for intake hopper). **(6)**
- Double deck casings. **(7)**
- Casing with flow regulation system (manual control). **(8)**
- Elbow casing (for inclination changing).
- PE-UHMW chain sliding bloks with metallic central guide.

Discharging slide

- Longitudinal opening with limit sensors.
- Electric (9), pneumatic (10) or manual control.
- Chain brushing system at the intermediate outlets.

Accessories

- Standard inlet hopper.
- Discharging hopper with square outlet.
- Adjustable supporting legs. **(11)**

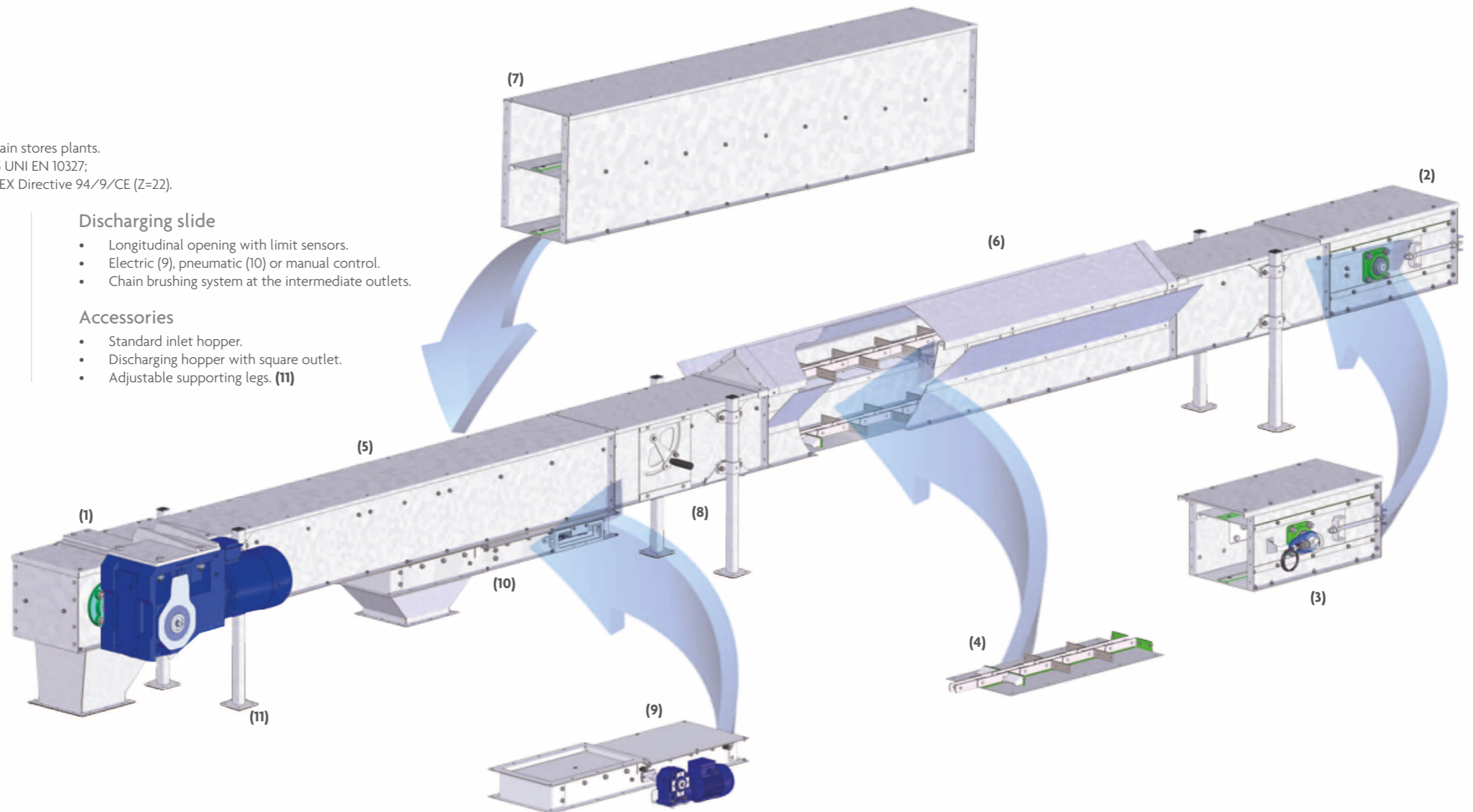

		TCA.60	TCA.120	TCA.150	TCA.200
Capacity ⁽¹⁾	t/h	60	120	150	200
Capacity ⁽¹⁾	bph	2183	4366	5457	7276
Max Power	kW	15	15	18,5	22
Dimensions: W / W1 / H	mm	200 / 295 / 347	300 / 395 / 347	350 / 448 / 445	400 / 498 / 445
Dimensions: A / B	mm	750 / 750		1000 / 750	
Head Thickness ⁽²⁾	mm	3,0 - 3,0 ⁽³⁾ - 1,5	3,0 - 3,0 ⁽³⁾ - 1,5	4,0 - 4,0 ⁽³⁾ - 2,0	4,0 - 4,0 ⁽³⁾ - 2,0
Tail Thickness ⁽²⁾	mm	3,0 - 3,0 ⁽³⁾ - 1,5	3,0 - 3,0 ⁽³⁾ - 1,5	4,0 - 4,0 ⁽³⁾ - 2,0	4,0 - 4,0 ⁽³⁾ - 2,0
Casings Thickness ⁽²⁾	mm	2,5 - 3,0 ⁽³⁾ - 1,5	2,5 - 3,0 ⁽³⁾ - 1,5	3,0 - 4,0 ⁽³⁾ - 2,0	3,0 - 4,0 ⁽³⁾ - 2,0
Version ⁽⁴⁾	-	ISO	ISO	ISO	ISO
Design Working Load ⁽⁵⁾	h/y	2200	2200	2200	2200

⁽¹⁾ Capacities are referred to dry cereal (r.h. 14%), with bulk density 0,78 t/m³ and impurities lower than 4%

⁽²⁾ Thickness: Flanks - Bottom - Cover

⁽³⁾ As an option the conveyor can be supplied with PE-UHMW bottom lining

⁽⁴⁾ ISO Version = Bent-Links Scraper Chain

⁽⁵⁾ Design working load has been considered for dry cereal (r.h. 14%), with bulk density 0,78 kg/m³ and impurities lower than 4%

^(*) L = 2400 / 1900 / 1400 / 900 / 400 mm (Special dimensions available upon request) - Standard elbow casings (from horizontal to inclined and from inclined to horizontal): 5° - 10° - 15°

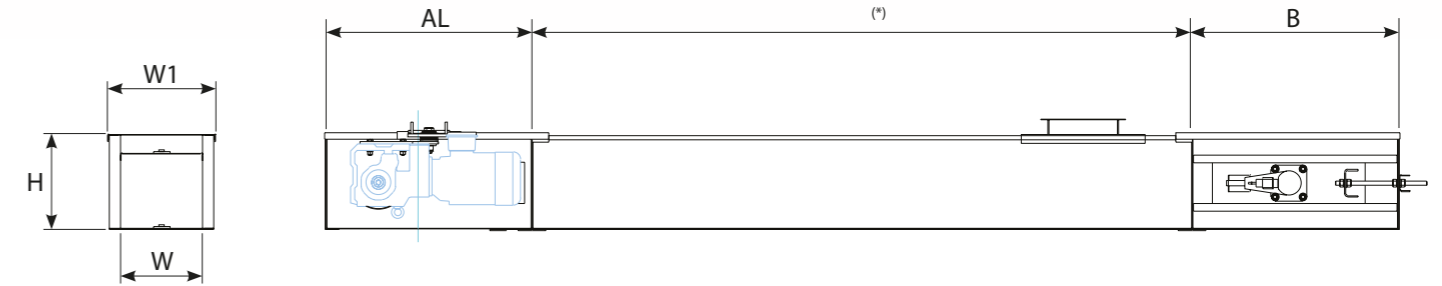

CHAIN CONVEYOR

GENERAL CHARACTERISTICS

- Design for the transport of granular or dusty products (typically cereals, oilseeds, flour, meals and their by-products).
- Wide range of machines. Customization according to the customer's requirements.
- Surface treatment by hot-dip galvanization or epoxidic dust painting (also for human food).
- Standard execution (CE) or in compliance with ATEX Directive 94/9/CE (Z=22).

Drive head

- Drive unit direct coupled to the shaft. (1)
- Drive head with motor, reducer and joints, complete with support. (2)
- Anti-clogging system and inspection window.
- Self-cleaning drive head ("drum" type).

Tail

- Standard tensioning system by screws (internal or external). (3)
- Tensioning system with spring buckets. (4)
- Tensioning slides with self-aligning bearings.
- Speed monitoring system.
- Special execution for reversible machine.
- Dust tight tail (for application with dusty products).

Casings

- Standard casings. (7)
- Side-inlet casings (for intake hopper). (8)
- Double deck casings. (9)
- Casing with flow regulation system. (10)
- Elbow casing (for inclination changing).
- PE-UHMW chain rails with metallic central guide.
- PE-UHMW bottom coating.
- Reinforced steel bottom.

Conveying chain

- Belt-link scraper chains. (5)
- Drop-forged chains. (6)
- PE-UHMW scrapers (standard or for human food).
- Recovery buckets.

Discharging slide

- Longitudinal opening. (11)
- Transversal opening. (12)
- Electric, pneumatic or manual control.
- Limit sensors.
- Chain brushing system at the intermediate outlets.

Accessories

- Standard inlet hopper.
- Inlet hopper with flow regulation system.
- Side inlet hopper.
- Discharging hopper.
- Stainless steel outlet hopper with magnetic separator.
- Adjustable supporting legs.
- Inspection windows.

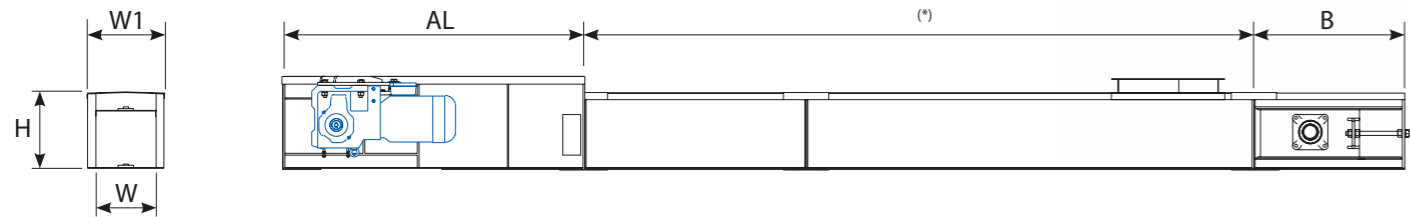
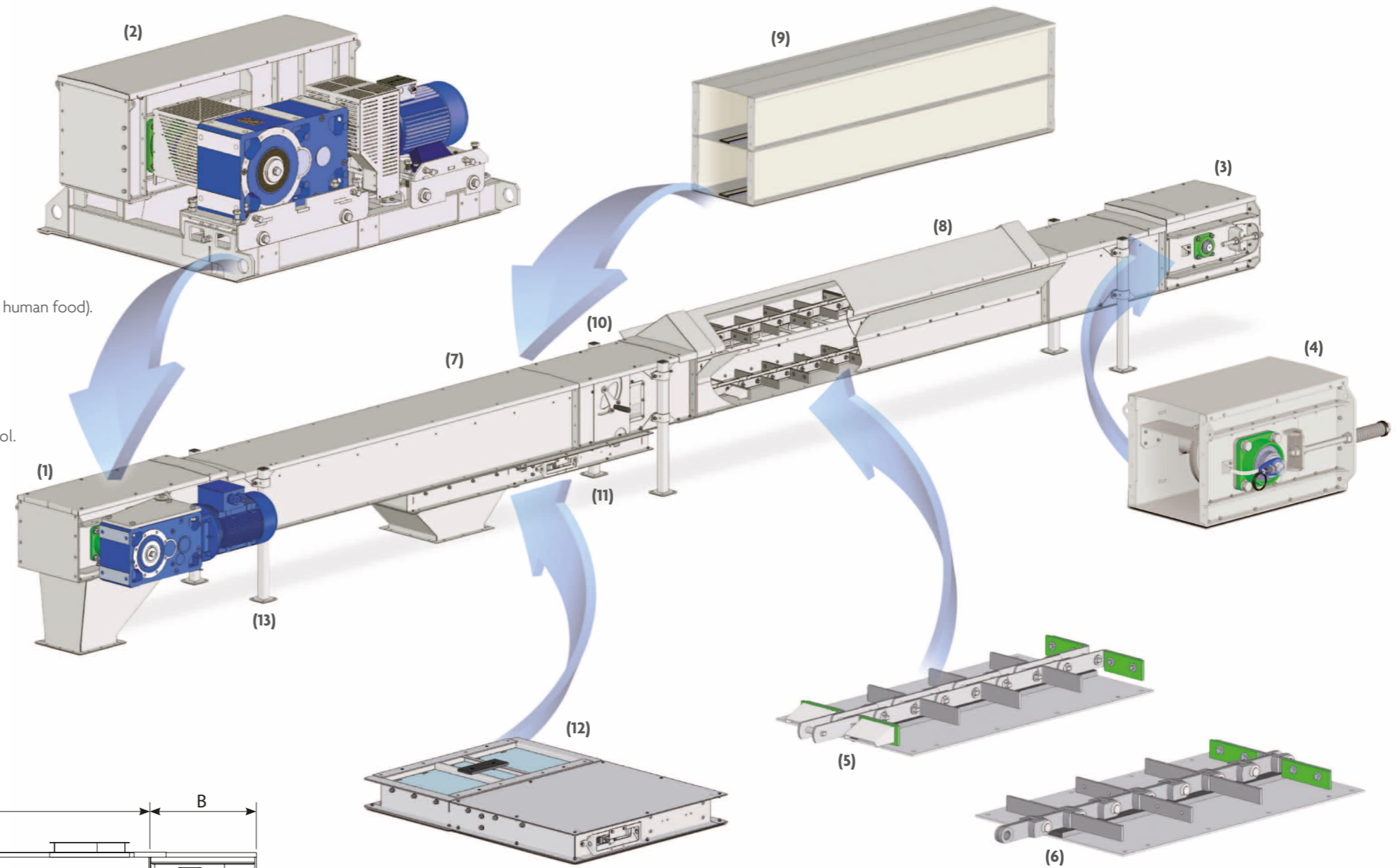

		TCM.320.160	TCM.320.200	TCM.400.200	TCM.400.250	TCM.400.300	TCM.400.350	TCM.400.400	
Capacity (1)	t/h	40	60	80	100	120	150	200	
Capacity (1)	bph	1455	2183	2911	3638	4366	5457	7276	
Max Power	kW	9,2			30				
Dimensions: W / W1 / H	mm	160 / 230 / 330	200 / 270 / 330	200 / 316 / 420	250 / 370 / 420	300 / 416 / 420	350 / 465 / 420	400 / 515 / 420	
Dimensions: A / B	mm	1000 / 700			1250 / 750				
Head Thickness (2)	mm	3,0 - 3,0(3) - 1,5			5,0 - 4,0(3) - 2,0				
Tail Thickness (2)	mm	3,0 - 3,0(3) - 1,5			3,0 - 4,0(3) - 2,0				
Casings Thickness (2)	mm	2,5 - 3,0(3) - 1,5			3,0 - 4,0(3) - 2,0				
Version (4)	-	ISO	ISO	ISO	R	ISO	R	ISO	R
Design Working Load (5)	h/y	5000			5000				

(1) Capacities are referred to dry cereal (r.h. 14%), with bulk density 0,78 t/m³ and impurities lower than 4%
 (2) Thickness: Flanks - Bottom - Cover
 (3) As an option the conveyor can be supplied with reinforced steel bottom or with PE-UHMW bottom lining (also for human food)
 (4) ISO Version = Bent-Links Scraper Chain - R Version = Drop-Forged Scraper Chain
 (5) Design working load has been considered for dry cereal (r.h. 14%), with bulk density 0,78 kg/m³ and impurities lower than 4%
 (*) L = 2970 / 2470 / 1980 / 1470 / 990 / 490 mm (Special dimensions available upon request) - Standard elbow casings (from horizontal to inclined and from inclined to horizontal): 5° - 10° - 15°

TCM.440.350		TCM.440.400		TCM.550.400		TCM.550.450		TCM.550.500		TCM.630.450		TCM.630.500		TCM.630.600		TCM.630.600H	
200	250	250	300	350	400	500	600	800									
7276	9095	9095	10914	12734	14553	18191	21829	29105									
9,2				7,5				13,2									
350 / 471 / 515	400 / 521 / 515	400 / 525 / 610	450 / 575 / 610	500 / 625 / 610	450 / 575 / 660	500 / 625 / 660	600 / 725 / 660	600 / 740 / 830									
2000 / 1000		2000 / 1000		2000 / 1000		2750 / 1250											
6,0 - 6,0(3) - 2,0		6,0 - 6,0(3) - 3,0		6,0 - 6,0(3) - 3,0		6,0 - 8,0(3) - 3,0											
5,0 - 6,0(3) - 2,0		5,0 - 6,0(3) - 3,0		5,0 - 6,0(3) - 3,0		5,0 - 8,0(3) - 3,0											
4,0 - 6,0(3) - 2,0		4,0 - 6,0(3) - 3,0		5,0 - 6,0(3) - 3,0		5,0 - 8,0(3) - 3,0											
ISO	R	ISO	R	ISO	R	ISO	R	ISO	R	ISO	R	ISO	R	ISO	R	ISO	
5000				5000				5000									

(1) Capacities are referred to dry cereal (r.h. 14%), with bulk density 0,78 t/m³ and impurities lower than 4%
 (2) Thickness: Flanks - Bottom - Cover
 (3) As an option the conveyor can be supplied with reinforced steel bottom or with PE-UHMW bottom lining (also for human food)
 (4) ISO Version = Bent-Links Scraper Chain - R Version = Drop-Forged Scraper Chain
 (5) Design working load has been considered for dry cereal (r.h. 14%), with bulk density 0,78 kg/m³ and impurities lower than 4%
 (*) L = 2970 / 2470 / 1980 / 1470 / 990 / 490 mm (Special dimensions available upon request) - Standard elbow casings (from horizontal to inclined and from inclined to horizontal): 5° - 10° - 15°

➤ ACCESSORIES

SPOUT & CONNECTIONS

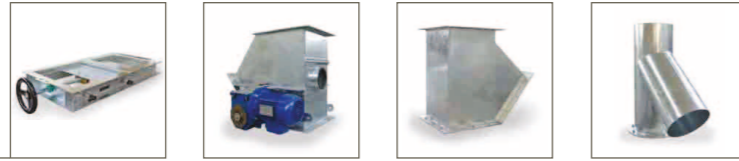

A complete range of accessories for the detection and deviation of the product and for the connection of several components:

- **Detection slides:** with square and rectangular section, with manual, electric or pneumatic control;
- **Diverter valves:** 2-ways and 3-ways, symmetrical and asymmetrical, with manual, electric or pneumatic control;
- **Connection components with round and square section:** absorber boxes, connections, elbows, brakes and hoppers, section reductions, etc.

VENTILATION COMPONENTS

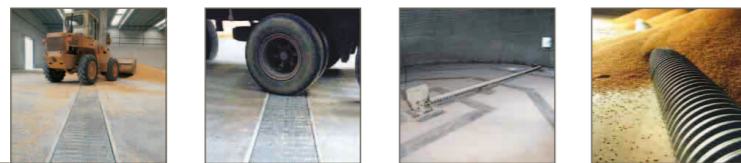

Three product lines are available:

- Self-locking panels type LM 124 (pedestrian for vertical silos, for the covering of air distribution channels imbedded in foundation);
- Self-locking panels type LM 74 accessible to vehicles, for flat stores, for the covering of air distribution channels imbedded in foundation);
- Ventilation ducts type CM 160 (for silos and stores with already existing pavements).

SAMPLING SYSTEMS



The following items are available:

- The circuit sampling system **CSM**. It takes samples of any grain product at a given point of the circuit (for example, at the discharging point of a dryer). The control and command device is expected to take samples at regular and planned intervals, excellent sampling is guaranteed by this application.
- The sampling probe from truck **PREVRAC**. It provides a representative sampling (7 levels probing, without aspiration), fast (within 40 sec from truck stop) and safe (fully equipped with safety device) of a grain product while it is in the truck. The sampling is directly sent to the analysis lab through a pneumatic transport system.



FILTERS FOR INTAKE PITS

FTM high pressure filters have been studied to guarantee the lowering of dust during the unloading of the vehicles in the receiving hopper. The modular construction allows the match of several elements in order to guarantee an homogeneous detection of dusts on all the hopper length.

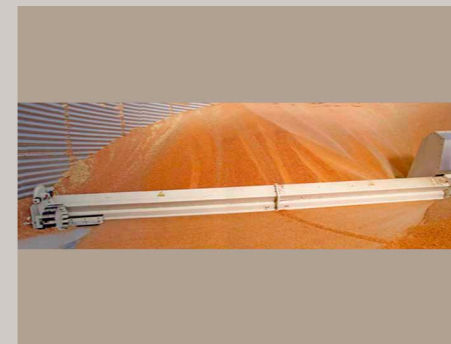

MORILLON SWEEP AUGER

Our partner for sweep auger



BULK WEIGHERS



JET FILTERS



AERATION SYSTEM

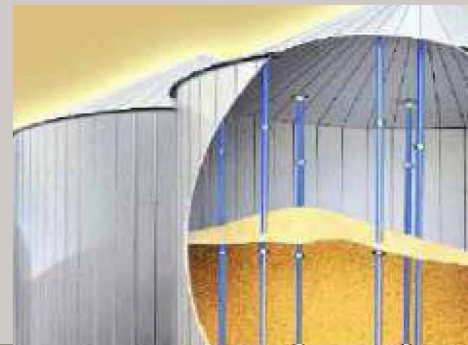

TEMPERATURE SYSTEM



DRUM CLEANERS



ECCOLOGIC RECEPTION HOPPERS

WIDE-CORR CENTURION FLAT BOTTOM SILOS



ENGINEERED WITH WESTEEL'S ADVANCED UPRIGHT STIFFENING SYSTEM.

Wide-Corr Centurion grain bins and hopper tanks represent the latest in grain storage technology and are designed for the rigors of commercial applications, including use in the biofuels industry. Westeel products are built to withstand the extra stress caused by continuous use, extreme temperatures, high winds and heavy snow loads. They employ Westeel's advanced upright stiffening system, which allows for a more efficient use of steel as well as the ability to maximize bin strength where load stress is greatest. This stiffening system can also be adapted to meet different load requirements of specific installations, as additional stiffening can be added near points of greater load, such as under catwalks. Finally, Wide-Corr Centurion grain bins and hopper tanks offer greater resistance to corrosion and the elements thanks to the use of thicker galvanization on the wall sheets.

SUPER STRONG SIDEWALL SHEETS

Wide-Corr Centurion sidewall sheets are made from G115 galvanized steel which is 25% heavier than the traditional industry standard G90. The result is greater protection against the elements and longer bin life. Most sheets are also rolled from high strength 50-ksi steel and are 44" tall, which means you use fewer sheets that are lighter but stronger; therefore, fewer seams for improved weather protection. Their ultra flat 4" corrugation pattern provides superior clean-out without compromising structural strength.

HIGH STRENGTH BOLTS

Alapala double bolts (triple on some large diameter bins) all sidewall sheets with high strength Grade 8.2 JS500 zinc plated bolts. Polyethylene washers ensure a weather-tight seal for each bolt.

HEAVY BOTTOM ANGLE

A heavy bottom angle is used to secure the bin and ensure a positive seal between the sidewall and foundation.

VARIABLE SECTION STIFFENERS (VSS)

Wide-Corr Centurion uses an innovative upright technology called Variable Section Stiffener (VSS) which works on the principle that the greater the vertical load required, the larger the stiffener section should be. This means the uprights and the section change in thickness from top to bottom. For additional value, our new upright laminating system allows the use of pre-galvanized material and minimizes the use of the splice plates in most connections.

SPECIALLY DESIGNED CRAWL DOOR

Factory assembled and installed, Wide-Corr Centurion features a standard heavy-duty 24" diameter crawl door manufactured on a heavy wall sheet for secure fit and easy access.

STRONGER, EASIER TO INSTALL ROOF

Alapala all-new patented commercial series roof has been designed for faster assembly and improved overall strength. Manufactured using the latest in computerized automated production equipment, this new roof features fewer parts than the competition and an innovative design making it the fastest and easiest roof to install in the industry. The number of roof vent openings (if required) can be customized and pre-punched during the manufacturing process. Roof strength has also been improved thanks to 100% bolting on all roof panels and a tight middle connection. For extra insurance against sagging and leaking from heavy loads of snow or ice, heavy beam roof framing supports with patented continuous ring purlins, and tension plates have also been incorporated.

OPTIONAL ACCESSORIES

- Roof vents • Drive through door • Catwalk • Wall ladders • Safety cage • Platforms • Circular stairs
- Roof stairs • Aeration systems • Side draw and accessories • Grain handling equipment • EasyCheck™ temperature and moisture cables • Wind rings
- Roof inspection hatch reinforcing kit



- A Bin wall and roof are strong enough to carry required equipment and conveyor loads
- B Heavy-duty wall stiffeners provide extra strength
- C Anchor bolts at each stiffener secure the bin to the foundation
- D Bolted connections and curved "Z" sections at roof transition provides tight, sealed connections
- E Curved tube supports and "Z" sections provide 100% contact and support to the roof panels with no gaps
- F Variable Section Stiffeners (VSS)
- G The snug fitting inner and outer door combination (structurally integrated in silo cylinder) provides a weather and grain seal

WIDE-CORR CENTURION FLAT BOTTOM SILOS

Wide-Corr® Centurion® Flat Bottom Bin Specifications

MODEL NUMBER	TIERS	DIAMETER		CAPACITY(1)			EAVES HEIGHT		OVERALL HEIGHT	
		#	ft	m	bu(2)	m³	tonnes(3)	ft	m	ft
1513	13	14' 11"	4.55	7260	244	197	47' 10"	14.58	51' 10"	15.78
1514	14	14' 11"	4.55	7800	262	212	51' 6"	15.70	55' 6"	16.90
1813	13	17' 11"	5.46	10510	353	285	47' 10"	14.58	52' 8"	16.05
1814	14	17' 11"	5.46	11290	379	306	51' 6"	15.70	56' 4"	17.16
2113	13	20' 11"	6.37	14390	484	390	47' 10"	14.58	53' 7"	16.31
2114	14	20' 11"	6.37	15450	519	419	51' 6"	15.70	57' 3"	17.42
2413	13	23' 10"	7.28	18900	635	513	47' 10"	14.58	54' 5"	16.57
2414	14	23' 10"	7.28	20280	682	550	51' 6"	15.70	58' 1"	17.69
2415	15	23' 10"	7.28	21670	728	588	55' 2"	16.81	61' 9"	18.80
2416	16	23' 10"	7.28	23050	775	625	58' 10"	17.93	65' 5"	19.92
2417	17	23' 10"	7.28	24440	821	663	62' 6"	19.05	69' 1"	21.04
2418	18	23' 10"	7.28	25820	868	700	66' 2"	20.17	72' 9"	22.16
2713	13	26' 10"	8.19	24050	809	652	47' 10"	14.58	55' 3"	16.83
2714	14	26' 10"	8.19	25800	868	700	51' 6"	15.70	58' 11"	17.95
2715	15	26' 10"	8.19	27550	926	747	55' 2"	16.81	62' 7"	19.07
2716	16	26' 10"	8.19	29310	985	795	58' 10"	17.93	66' 3"	20.19
2717	17	26' 10"	8.19	31060	1044	843	62' 6"	19.05	70' 0"	21.30
2718	18	26' 10"	8.19	32810	1103	890	66' 2"	20.17	73' 8"	22.42
3013	13	29' 10"	9.10	29850	1004	810	47' 10"	14.58	55' 8"	17.09
3014	14	29' 10"	9.10	32020	1077	868	51' 6"	15.70	59' 4"	18.21
3015	15	29' 10"	9.10	34180	1149	927	55' 2"	16.81	63' 0"	19.33
3016	16	29' 10"	9.10	36340	1222	986	58' 10"	17.93	66' 9"	20.45
3017	17	29' 10"	9.10	38510	1295	1045	62' 6"	19.05	70' 5"	21.56
3018	18	29' 10"	9.10	40670	1367	1103	66' 2"	20.17	74' 1"	22.68
3019	19	29' 10"	9.10	42840	1440	1162	69' 10"	21.29	77' 9"	23.80
3020	20	29' 10"	9.10	45000	1512	1221	73' 6"	22.40	81' 5"	24.92
3313	13	32' 10"	10.01	36310	1222	985	47' 10"	14.58	56' 7"	17.22
3314	14	32' 10"	10.01	38930	1310	1056	51' 6"	15.70	60' 3"	18.34
3315	15	32' 10"	10.01	41550	1398	1127	55' 2"	16.81	63' 11"	19.45
3316	16	32' 10"	10.01	44170	1485	1198	58' 10"	17.93	67' 7"	20.57
3317	17	32' 10"	10.01	46790	1573	1269	62' 6"	19.05	71' 3"	21.69
3318	18	32' 10"	10.01	49410	1661	1340	66' 2"	20.17	74' 11"	22.81
3319	19	32' 10"	10.01	52030	1749	1411	69' 10"	21.29	77' 9"	23.92
3320	20	32' 10"	10.01	54650	1837	1482	73' 6"	22.40	82' 3"	25.04
3321	21	32' 10"	10.01	57270	1925	1553	77' 2"	23.52	85' 11"	26.16
3322	22	32' 10"	10.01	59880	2013	1624	80' 10"	24.64	89' 7"	27.28
3323	23	32' 10"	10.01	62500	2100	1695	84' 6"	25.76	93' 3"	28.39
3613	13	35' 10"	10.91	43450	1462	1178	47' 10"	14.58	57' 5"	17.48
3614	14	35' 10"	10.91	46560	1567	1263	51' 6"	15.70	61' 1"	18.60
3615	15	35' 10"	10.91	49680	1671	1348	55' 2"	16.81	64' 9"	19.72
3616	16	35' 10"	10.91	52800	1776	1432	58' 10"	17.93	68' 5"	20.83
3617	17	35' 10"	10.91	55920	1881	1517	62' 6"	19.05	72' 1"	21.95
3618	18	35' 10"	10.91	59030	1985	1601	66' 2"	20.17	75' 9"	23.07
3619	19	35' 10"	10.91	62150	2090	1686	69' 10"	21.29	79' 5"	24.19
3620	20	35' 10"	10.91	65270	2194	1770	73' 6"	22.40	83' 1"	25.30
3621	21	35' 10"	10.91	68380	2299	1855	77' 2"	23.52	86' 9"	26.42
3622	22	35' 10"	10.91	71500	2403	1939	80' 10"	24.64	90' 5"	27.54
3623	23	35' 10"	10.91	74620	2508	2024	84' 6"	25.76	94' 1"	28.66
3913	13	38' 10"	11.82	51270	1726	1391	47' 10"	14.58	58' 3"	17.76
3914	14	38' 10"	11.82	54920	1849	1490	51' 6"	15.70	61' 11"	18.88
3915	15	38' 10"	11.82	58580	1971	1589	55' 2"	16.82	65' 7"	20.00
3916	16	38' 10"	11.82	62240	2094	1688	58' 10"	17.93	69' 3"	21.12
3917	17	38' 10"	11.82	65900	2217	1787	62' 6"	19.05	72' 11"	22.23
3918	18	38' 10"	11.82	69580	2340	1887	66' 2"	20.17	76' 8"	23.36
3919	19	38' 10"	11.82	73240	2463	1986	69' 10"	21.29	80' 4"	24.47
3920	20	38' 10"	11.82	76890	2586	2086	73' 6"	22.41	84' 0"	25.59
3921	21	38' 10"	11.82	80550	2708	2185	77' 2"	23.53	87' 8"	26.71
3922	22	38' 10"	11.82	84210	2831	2284	80' 10"	24.65	91' 4"	27.83
3923	23	38' 10"	11.82	87870	2954	2383	84' 6"	25.76	95' 0"	28.95
4213	13	41' 9"	12.73	59770	2013	1621	47' 10"	14.58	59' 2"	18.01
4214	14	41' 9"	12.73	64010	2155	1736	51' 6"	15.70	62' 10"	19.12
4215	15	41' 9"	12.73	68260	2297	1851	55' 2"	16.81	66' 6"	20.24
4216	16	41' 9"	12.73	72500	2440	1966	58' 10"	17.93	70' 2"	21.36
4217	17	41' 9"	12.73	76740	2582	2082	62' 6"	19.05	73' 10"	22.48
4218	18	41' 9"	12.73	80980	2724	2197	66' 2"	20.17	77' 6"	23.59
4219	19	41' 9"	12.73	85230	2867	2312	69' 10"	21.29	81' 2"	24.71
4220	20	41' 9"	12.73	89470	3009	2427	73' 6"	22.40	84' 10"	25.83
4221	21	41' 9"	12.73	93710	3151	2542	77' 2"	23.52	88' 6"	26.95
4222	22	41' 9"	12.73	97950	3294	2657	80' 10"	24.64	92' 2"	28.06
4223	23	41' 9"	12.73	102200	3436	2772	84' 6"	25.76	95' 10"	29.18
4513	13	44' 9"	13.64	68980	2323	1871	47' 10"	14.58	60' 0"	18.29
4514	14	44' 9"	13.64	73850	2487	2003	51' 6"	15.70	63' 8"	19.41
4515	15	44' 9"	13.64	78720	2650	2135	55' 2"	16.82	67' 4"	20.52
4516	16	44' 9"	13.64	83590	2814	2267	58' 10"	17.93	71' 0"	21.64
4517	17	44' 9"	13.64	88460	2977	2400	62' 6"	19.05	74' 8"	22.76
4518	18	44' 9"	13.64	93330	3140	2532	66' 2"	20.17	78' 4"	23.88
4519	19	44' 9"	13.64	98200	3305	2664	69' 10"	21.29	82' 0"	25.00
4520	20	44' 9"	13.64	103100	3468	2797	73' 6"	22.41	85' 8"	26.12
4521	21	44' 9"	13.64	107970	3631	2929	77' 2"	23.53	89' 4"	27.24
4522	22	44' 9"	13.64	112840	3795	3061	80' 10"	24.65	93' 0"	28.35
4523	23	44' 9"	13.64	117710	3958	3193	84' 6"	25.76	96' 8"	29.47

MODEL NUMBER	TIERS	DIAMETER		CAPACITY(1)			EAVES HEIGHT		OVERALL HEIGHT	
		#	ft	m	bu(2)	m³	tonnes(3)	ft	m	ft
4813	13	47' 9"	14.55	78900	2658	2140	47' 10"	14.58	60' 10"	18.55
4814	14	47' 9"	14.55	84440	2844	2290	51' 6"	15.70	64' 6"	19.65
4815	15	47' 9"	14.55	89980	3030	2441	55' 2"	16.81	68' 2"	20.77
4816	16	47' 9"	14.55	95520	3216	2591	58' 10"	17.93	71' 10"	21.88
4817	17	47' 9"	14.55	101060	3402	2741	62' 6"	19.05	75' 6"	23.00
4818	18	47' 9"	14.55	106600	3587	2892	66' 2"	20.17	79' 3"	24.12
4819	19	47' 9"	14.55	112140	3773	3042	69' 10"	21.29	82' 11"	25.24
4820	20	47' 9"	14.55	117690	3959	3192	73' 6"	22.40	86' 7"	26.36
4821	21	47' 9"	14.55	123230	4145	3342	77' 2"	23.52	90' 3"	27.47
4822	22	47' 9"	14.55	128770	4331	3493	80' 10"	24.64	93' 11"	28.59
4823	23	47' 9"	14.55	134310	4517	3643	84' 6"	25.76	97' 7"	29.71
5109	09	50' 9"	15.46	63890	2156	1733	33' 2"	10.11	46' 11"	14.28
5110	10	50' 9"	15.46	70150	2366	1903	36' 8"	11.23	50' 6"	15.40
5111	11	50' 9"	15.46	76410	2576	2072	40' 6"	12.35	54' 2"	16.52
5112	12	50' 9"	15.46	82670	2785	2242	44' 2"	13.46	57' 11"	17.64
5113	13	50' 9"	15.46	88920	2995	2412	47' 10"	14.58	61' 6"	18.75
5114	14	50' 9"	15.46	95170	3205	2581	51' 6"	15.70	65' 2"	19.87
5115	15	50' 9"	15.46	101430	3415	2751	55' 2"	16.82	68' 10"	20.99
5116	16	50' 9"	15.46	107680	3625	2921	58' 10"	17.93	72' 6"	22.11
5117	17	50' 9"	15.46	113940	3835	3091	62' 6"	19.05	76' 3"	23.23
5118	18	50' 9"	15.46	120200	4045	3260	66' 2"	20.17	79' 11"	24.34
5119	19	50' 9"	15.46	126490	4256	3431	69' 10"	21.29	83' 7"	25.47
5120	20	50' 9"	15.46	132740	4466	3601	73' 6"	22.41	87' 3"	26.58
5121	21	50' 9"	15.46	139000	4675	3770	77' 2"	23.53	90' 11"	27.70
5122	22	50' 9"	15.46	145250	4885	3940	80' 10"	24.65	94' 7"	28.82
5123	23	50' 9"	15.46	151510	5095	4110	84' 6"	25.76	98' 3"	29.94
5409(4)	9	53' 9"	16.37	72110	2434	1956	33' 2"	10.11	47' 9"	14.55
5410(4)	10	53' 9"</								

WIDE-CORR CENTURION FLAT BOTTOM SILOS

Wide-Corr® Centurion® Flat Bottom Bin Specifications

MODEL NUMBER	TIERS	DIAMETER		CAPACITY(1)			EAVES HEIGHT		OVERALL HEIGHT	
		#	ft	m	bu(2)	m³	tonnes(3)	ft	m	ft
7219	19	71' 7"	21.83	257800	8683	6993	69' 10"	21.29	90' 2"	27.55
7220	20	71' 7"	21.83	270270	9102	7331	73' 6"	22.40	93' 10"	28.67
7221	21	71' 7"	21.83	282740	9520	7669	77' 2"	23.52	97' 6"	29.78
7222	22	71' 7"	21.83	295200	9938	8007	80' 10"	24.64	101' 2"	30.90
7223	23	71' 7"	21.83	307670	10356	8345	84' 6"	25.76	104' 10"	32.02
7809	9	77' 7"	23.65	158240	5353	4292	33' 2"	10.11	55' 2"	16.90
7810	10	77' 7"	23.65	172870	5844	4689	36' 10"	11.23	58' 10"	18.01
7811	11	77' 7"	23.65	187510	6334	5086	40' 6"	12.34	62' 6"	19.13
7812	12	77' 7"	23.65	202140	6825	5483	44' 2"	13.46	66' 2"	20.25
7813	13	77' 7"	23.65	216770	7316	5880	47' 10"	14.58	69' 10"	21.37
7814	14	77' 7"	23.65	231400	7807	6277	51' 6"	15.70	73' 6"	22.48
7815	15	77' 7"	23.65	246040	8298	6674	55' 2"	16.81	77' 2"	23.60
7816	16	77' 7"	23.65	260670	8789	7070	58' 10"	17.93	80' 10"	24.72
7817	17	77' 7"	23.65	275300	9280	7467	62' 6"	19.05	84' 6"	25.84
7818	18	77' 7"	23.65	289930	9771	7864	66' 2"	20.17	88' 2"	26.95
7819	19	77' 7"	23.65	304570	10262	8261	69' 10"	21.29	91' 10"	28.07
7820	20	77' 7"	23.65	319200	10753	8658	73' 6"	22.40	95' 6"	29.19
7821	21	77' 7"	23.65	333830	11243	9055	77' 2"	23.52	99' 2"	30.31
7822	22	77' 7"	23.65	348460	11734	9452	80' 10"	24.64	102' 10"	31.42
7823	23	77' 7"	23.65	363100	12225	9849	84' 6"	25.76	106' 6"	32.54
8409	9	83' 7"	25.47	186160	6300	5049	33' 2"	10.11	56' 11"	17.34
8410	10	83' 7"	25.47	203130	6869	5510	36' 10"	11.23	60' 7"	18.46
8411	11	83' 7"	25.47	220100	7439	5970	40' 6"	12.35	64' 3"	19.58
8412	12	83' 7"	25.47	237070	8008	6430	44' 2"	13.46	67' 11"	20.70
8413	13	83' 7"	25.47	254040	8577	6891	47' 10"	14.58	71' 7"	21.82
8414	14	83' 7"	25.47	271010	9147	7351	51' 6"	15.70	75' 3"	22.93
8415	15	83' 7"	25.47	287980	9716	7811	55' 2"	16.82	78' 11"	24.05
8416	16	83' 7"	25.47	304950	10285	8271	58' 10"	17.93	82' 7"	25.17
8417	17	83' 7"	25.47	322010	10858	8734	62' 6"	19.06	86' 3"	26.29
8418	18	83' 7"	25.47	339080	11427	9195	66' 2"	20.17	89' 11"	27.41
8419	19	83' 7"	25.47	355950	11997	9655	69' 10"	21.29	93' 7"	28.53
8420	20	83' 7"	25.47	372920	12566	10115	73' 6"	22.41	97' 3"	29.64
8421	21	83' 7"	25.47	389890	13135	10576	77' 2"	23.53	100' 11"	30.76
8422	22	83' 7"	25.47	406870	13705	11036	80' 10"	24.65	104' 7"	31.88
8423	23	83' 7"	25.47	423840	14274	11496	84' 6"	25.76	108' 3"	33.00
9009	9	89' 6"	27.29	216030	7315	5860	33' 2"	10.11	58' 8"	17.95
9010	10	89' 6"	27.29	235510	7968	6388	36' 10"	11.23	62' 4"	19.07
9011	11	89' 6"	27.29	254990	8622	6916	40' 6"	12.34	66' 0"	20.18
9012	12	89' 6"	27.29	274470	9275	7445	44' 2"	13.46	69' 8"	21.30
9013	13	89' 6"	27.29	293950	9929	7973	47' 10"	14.58	73' 4"	22.42
9014	14	89' 6"	27.29	313430	10583	8502	51' 6"	15.70	77' 0"	23.54
9015	15	89' 6"	27.29	332920	11236	9030	55' 2"	16.81	80' 8"	24.65
9016	16	89' 6"	27.29	352400	11890	9558	58' 10"	17.93	84' 4"	25.77
9017	17	89' 6"	27.29	371880	12543	10087	62' 6"	19.05	88' 0"	26.89
9018	18	89' 6"	27.29	391360	13197	10615	66' 2"	20.17	91' 8"	28.01
9019	19	89' 6"	27.29	410840	13850	11144	69' 10"	21.29	95' 4"	29.12
9020	20	89' 6"	27.29	430320	14504	11672	73' 6"	22.40	99' 0"	30.24
9021	21	89' 6"	27.29	449800	15158	12200	77' 2"	23.52	102' 8"	31.36
9022	22	89' 6"	27.29	469280	15811	12729	80' 10"	24.64	106' 4"	32.48
9023	23	89' 6"	27.29	488760	16465	13257	84' 6"	25.76	110' 0"	33.59
9609	9	95' 6"	29.11	249230	8443	6760	33' 2"	10.11	60' 4"	18.39
9610	10	95' 6"	29.11	271400	9187	7361	36' 10"	11.23	64' 0"	19.51
9611	11	95' 6"	29.11	293560	9930	7963	40' 6"	12.35	67' 8"	20.63
9612	12	95' 6"	29.11	315730	10674	8564	44' 2"	13.46	71' 4"	21.75
9613	13	95' 6"	29.11	337890	11418	9165	47' 10"	14.58	75' 0"	22.87
9614	14	95' 6"	29.11	360060	12161	9766	51' 6"	15.70	78' 8"	23.98
9615	15	95' 6"	29.11	382220	12905	10367	55' 2"	16.82	82' 4"	25.10
9616	16	95' 6"	29.11	404380	13653	10972	58' 10"	17.93	86' 0"	26.22
9617	17	95' 6"	29.11	426540	14396	11573	62' 6"	19.06	89' 8"	27.34
9618	18	95' 6"	29.11	448700	15140	12175	66' 2"	20.17	93' 4"	28.46
9619	19	95' 6"	29.11	470860	15883	12776	69' 10"	21.29	97' 0"	29.58
9620	20	95' 6"	29.11	493020	16627	13377	73' 6"	22.41	100' 8"	30.69
9621	21	95' 6"	29.11	515180	17371	13978	77' 2"	23.53	104' 4"	31.81
9622	22	95' 6"	29.11	537340	18114	14579	80' 10"	24.65	108' 0"	32.93
9623	23	95' 6"	29.11	559500	18858	15181	84' 6"	25.76	111' 8"	34.05
10209	9	101' 6"	30.93	284800	9653	7725	33' 2"	10.11	61' 11"	18.86
10210	10	101' 6"	30.93	309820	10492	8404	36' 10"	11.23	65' 7"	19.98
10211	11	101' 6"	30.93	334840	11332	9082	40' 6"	12.35	69' 3"	21.10
10212	12	101' 6"	30.93	359860	12171	9761	44' 2"	13.46	72' 11"	22.21
10213	13	101' 6"	30.93	384880	13010	10440	47' 10"	14.58	76' 7"	23.33
10214	14	101' 6"	30.93	409900	13850	11118	51' 6"	15.70	80' 3"	24.45
10215	15	101' 6"	30.93	435070	14694	11801	55' 2"	16.82	83' 11"	25.57
10216	16	101' 6"	30.93	460100	15534	12480	58' 10"	17.93	87' 7"	26.69
10217	17	101' 6"	30.93	485120	16373	13158	62' 6"	19.06	91' 3"	27.81
10218	18	101' 6"	30.93	510140	17213	13837	66' 2"	20.17	94' 11"	28.93
10219	19	101' 6"	30.93	535160	18052	14516	69' 10"	21.29	98' 7"	30.04
10220	20	101' 6"	30.93	560190	18892	15195	73' 6"	22.41	102' 3"	31.16
10221	21	101' 6"	30.93	585210	19731	15873	77' 2"	23.53	105' 11"	32.28
10222	22	101' 6"	30.93	610230	20570	16552	80' 10"	24.65	109' 7"	33.40
10223	23	101' 6"	30.93	635250	21410	17231	84' 6"	25.76	113' 3"	34.51

MODEL NUMBER	TIERS	DIAMETER		CAPACITY(1)			EAVES HEIGHT		OVERALL HEIGHT	
		#	ft	m	bu(2)	m³	tonnes(3)	ft	m	ft
10809	9	107' 5"	32.74	323140	10957	8765	33' 2"	10.11	63' 7"	19.39
10810	10	107' 5"	32.74	351190	11898	9526	36' 10"	11.23	67' 3"	20.50
10811	11	107' 5"	32.74	379250	12840	10287	40' 6"	12.35	70' 11"	21.62
10812	12	107' 5"	32.74	407300	13781	11048	44' 2"	13.46	74' 7"	22.74
10813	13	107' 5"	32.74	435350	14722	11809	47' 10"	14.58	78' 3"	23.86
10814	14	107' 5"	32.74	463410	15663	12569	51' 6"	15.70	81' 11"	24.97
10815	15	107' 5"	32.74	491460	16609	13335	55' 2"	16.82	85' 7"	26.10
10816	16	107' 5"	32.74	519670	17551	14096	58' 10"	17.94	89' 3"	27.22
10817	17	107' 5"	32.74	547720	18492	14857	62' 6"	19.06	92' 11"	28.33
10818	18	107' 5"	32.74	575780	19433	15617	66' 2"	20.17	96' 7"	29.45
10819	19	107' 5"	32.74	603830	20374	16378	69' 10"	21.29	100' 3"	30.57
10820	20	107' 5"	32.74	631880	21315	17139	73' 6"	22.41	103' 11"	31.69
10821	21	107' 5"	32.74	659940	22256	17900	77' 2"	23.53	107' 7"	32.80
10822	22	107' 5"	32.74	687990	23197	18661	80' 10"	24.65	111' 3"	33.92

- Capacities based on: Models 1513 to 5123 – filled to eaves line with 30° roof cone. Models 5409 to 10822 – filled to 3/4" below eaves line with 28° roof cone.
- Based on 1.244 ft³/bu and 5% compaction below eaves line in cylinder (U.S. bushels).
- Based on 770 kg/m³ (48 lb/ft³) and 5% compaction below eaves line in cylinder.
- Roofs on all Wide-Corr Centurion Commercial Flat-Bottomed Bins 60' in diameter and above come structured, while all bins 51' in diameter and under are supplied unstructured. Roofs 54' in diameter (54 Series) are available structured or unstructured.

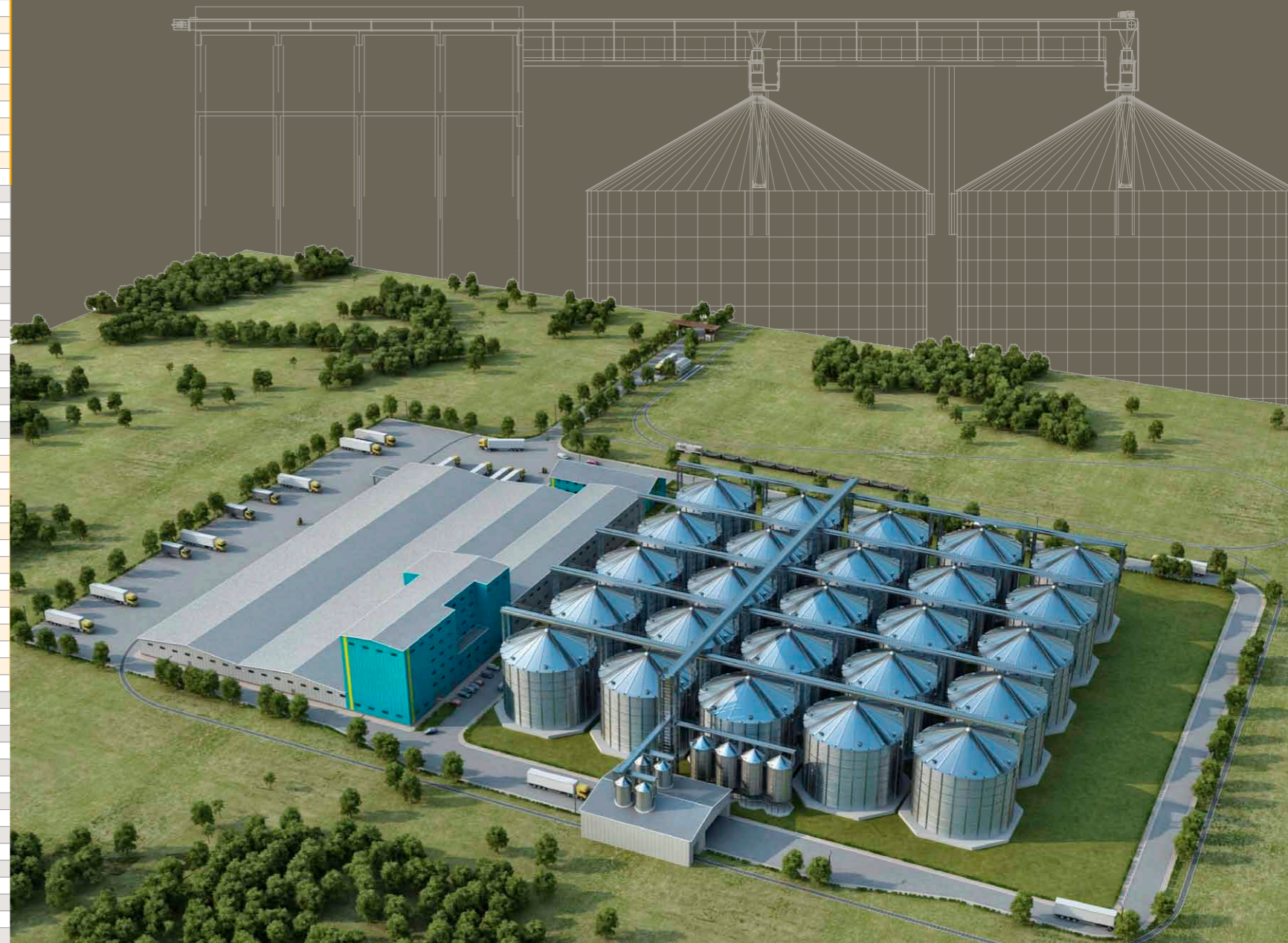

WIDE-CORR CENTURION HOPPER BOTTOM BINS



FEATURE GALVANIZED HOPPER PLATES SUPPORTED BY WESTEEL'S UNIQUE COMPRESSION RING ASSEMBLY FOR ADDITIONAL STRENGTH.

GALVANIZED HOPPERS

Wide-Corr Centurion hoppers feature galvanized hopper plates which are supported by Westeel's unique compression ring assembly for additional strength. This effectively transfers the bin load from the hopper onto the legs and into the bin foundation. A steel sealing strip is continuously welded to the compression ring assembly to ensure a moisture tight fit. Standard hopper features include caulking for all horizontal seams and a wide 14" discharge outlet. Larger discharges up to 22" are available as options for the ability to deliver rates up to 30,000 bu/hour. A 45° hopper cone is provided on all Series 15 to 24 hopper tanks, a 40° hopper cone for all Series 27 to 30 hopper tanks, and a 37° hopper cone for all Series 33 and 36 hopper tanks.

FULL I-BEAM LEG SUPPORT

For added strength and safety, Wide-Corr Centurion hoppers use full I-Beam construction for the leg support system. Cross-bracing manufactured from steel threaded rods is used between every leg to eliminate twisting and increase the structural rigidity of the base. Extra support is provided by the exterior stiffeners which are connected to the legs so that the bin loads are transferred directly to the concrete foundation. All components in the base structure are pre-punched at the factory for easy assembly.

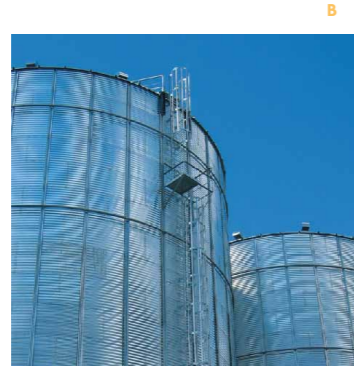

A The exterior stiffeners are attached directly to the legs so that the loads are transferred through to the concrete foundation
B Specially designed bins for unique applications ensure long lasting use even in the most rigorous applications

OPTIONAL ACCESSORIES

- Roof vents • Catwalk • Wall ladders • Safety cages • Platforms • Circular stairs • Roof stairs • Aeration systems • Leg extensions • Side draw and accessories • Larger customized discharge openings for hopper tanks • EasyCheck™ temperature and moisture cables • Roller and rack and pinion slide gates • Wind rings • Roof inspection hatch reinforcing kit

WIDE-CORR CENTURION HOPPER BOTTOM BINS

Wide-Corr® Centurion® Flat Bottom Bin Specifications

MODEL NUMBER	TIERS #	DIAMETER		CAPACITY(1)			OVERALL HEIGHT		HOPPER HEIGHT		LEGS #	HOPPER angle
		ft	m	bu(2)	m	tonnes(3)	ft	m	ft	m		
1507H45	7	14.92	4.55	4350	146	118	39.50	12.04	9.75	2.97	10	45°
1508H45	8	14.92	4.55	4890	165	133	43.17	13.16	9.75	2.97	10	45°
1509H45	9	14.92	4.55	5440	183	147	46.83	14.27	9.75	2.97	10	45°
1510H45	10	14.92	4.55	5980	201	162	50.50	15.39	9.75	2.97	10	45°
1511H45	11	14.92	4.55	6520	219	177	54.17	16.51	9.75	2.97	10	45°
1512H45	12	14.92	4.55	7060	237	192	57.83	17.63	9.75	2.97	10	45°
1513H45	13	14.92	4.55	7600	255	206	61.50	18.75	9.75	2.97	10	45°
1807H45	7	17.92	5.46	6440	217	175	42.00	12.80	11.33	3.45	12	45°
1808H45	8	17.92	5.46	7220	243	196	45.67	13.92	11.33	3.45	12	45°
1809H45	9	17.92	5.46	8000	269	217	49.33	15.04	11.33	3.45	12	45°
1810H45	10	17.92	5.46	8780	295	238	53.00	16.15	11.33	3.45	12	45°
1811H45	11	17.92	5.46	9560	321	259	56.67	17.27	11.33	3.45	12	45°
1812H45	12	17.92	5.46	10330	347	280	60.33	18.39	11.33	3.45	12	45°
1813H45	13	17.92	5.46	11110	373	302	64.00	19.51	11.33	3.45	12	45°
2107H45	7	20.92	6.38	8990	303	244	44.42	13.54	12.92	3.94	14	45°
2108H45	8	20.92	6.38	10050	338	273	48.08	14.66	12.92	3.94	14	45°
2109H45	9	20.92	6.38	11140	374	302	51.75	15.77	12.92	3.94	14	45°
2110H45	10	20.92	6.38	12170	409	330	55.42	16.89	12.92	3.94	14	45°
2111H45	11	20.92	6.38	13230	445	359	59.08	18.01	12.92	3.94	14	45°
2112H45	12	20.92	6.38	14290	481	388	62.75	19.13	12.92	3.94	14	45°
2113H45	13	20.92	6.38	15360	516	417	66.42	20.24	12.92	3.94	14	45°
2407H45	7	23.92	7.29	12040	405	327	46.75	14.25	14.42	4.39	16	45°
2408H45	8	23.92	7.29	13430	452	364	50.42	15.37	14.42	4.39	16	45°
2409H45	9	23.92	7.29	14810	498	402	54.08	16.48	14.42	4.39	16	45°
2410H45	10	23.92	7.29	16200	545	440	57.75	17.60	14.42	4.39	16	45°
2411H45	11	23.92	7.29	17580	591	477	61.42	18.72	14.42	4.39	16	45°
2412H45	12	23.92	7.29	18970	638	515	65.08	19.84	14.42	4.39	16	45°
2413H45	13	23.92	7.29	20350	684	552	68.75	20.96	14.42	4.39	16	45°
2414H45	14	23.92	7.29	21730	730	589	72.42	22.07	14.42	4.39	16	45°
2707H40	7	26.83	8.18	15280	515	415	47.00	14.33	13.75	4.19	18	40°
2708H40	8	26.83	8.18	17030	573	462	50.67	15.44	13.75	4.19	18	40°
2709H40	9	26.83	8.18	18790	632	510	54.33	16.56	13.75	4.19	18	40°
2710H40	10	26.83	8.18	20540	691	557	58.00	17.68	13.75	4.19	18	40°
2711H40	11	26.83	8.18	22290	750	605	61.67	18.80	13.75	4.19	18	40°
2712H40	12	26.83	8.18	24050	809	652	65.33	19.91	13.75	4.19	18	40°
2713H40	13	26.83	8.18	25800	868	700	69.00	21.03	13.75	4.19	18	40°
2714H40	14	26.83	8.18	27550	927	748	72.67	22.15	13.75	4.19	18	40°
3007H40	7	29.83	9.09	19280	649	523	49.08	14.96	15.00	4.57	20	40°
3008H40	8	29.83	9.09	21440	722	582	52.75	16.08	15.00	4.57	20	40°
3009H40	9	29.83	9.09	23600	795	641	56.42	17.20	15.00	4.57	20	40°
3010H40	10	29.83	9.09	25770	867	699	60.08	18.31	15.00	4.57	20	40°
3011H40	11	29.83	9.09	27930	940	758	63.75	19.43	15.00	4.57	20	40°
3012H40	12	29.83	9.09	30100	1012	817	67.42	20.55	15.00	4.57	20	40°
3013H40	13	29.83	9.09	32260	1085	875	71.08	21.67	15.00	4.57	20	40°
3014H40	14	29.83	9.09	34430	1158	934	74.75	22.78	15.00	4.57	20	40°
3307H37	7	32.83	10.01	23490	792	637	49.58	15.11	15.08	4.60	22	37°
3308H37	8	32.83	10.01	26110	880	708	53.25	16.23	15.08	4.60	22	37°
3309H37	9	32.83	10.01	28730	967	779	56.92	17.35	15.08	4.60	22	37°
3310H37	10	32.83	10.01	31350	1055	851	60.58	18.47	15.08	4.60	22	37°
3311H37	11	32.83	10.01	33960	1143	922	64.25	19.58	15.08	4.60	22	37°
3312H37	12	32.83	10.01	36580	1231	993	67.92	20.70	15.08	4.60	22	37°
3313H37	13	32.83	10.01	39200	1319	1064	71.58	21.82	15.08	4.60	22	37°
3314H37	14	32.83	10.01	41820	1407	1135	75.25	22.94	15.08	4.60	22	37°
3315H37	15	32.83	10.01	44440	1495	1206	78.92	24.05	15.08	4.60	22	37°
3316H37	16	32.83	10.01	47060	1583	1277	82.58	25.17	15.08	4.60	22	37°
3607H37	7	35.83	10.92	28510	961	774	51.58	15.72	16.25	4.95	24	37°
3608H37	8	35.83	10.92	31630	1066	858	55.25	16.84	16.25	4.95	24	37°
3609H37	9	35.83	10.92	34740	1170	943	58.92	17.96	16.25	4.95	24	37°
3610H37	10	35.83	10.92	37860	1275	1027	62.58	19.08	16.25	4.95	24	37°
3611H37	11	35.83	10.92	40980	1379	1112	66.25	20.19	16.25	4.95	24	37°
3612H37	12	35.83	10.92	44100	1484	1197	69.92	21.31	16.25	4.95	24	37°
3613H37	13	35.83	10.92	47210	1589	1281	73.58	22.43	16.25	4.95	24	37°
3614H37	14	35.83	10.92	50330	1693	1366	77.25	23.55	16.25	4.95	24	37°
3615H37	15	35.83	10.92	53450	1797	1451	80.92	24.66	16.25	4.95	24	37°
3616H37	16	35.83	10.92	56570	1901	1536	84.58	25.78	16.25	4.95	24	37°

1. Capacities based on: Models 1513 to 5123 – filled to eaves line with 30° roof cone. Models 5409 to 10822 – filled to 3/4" below eaves line with 28° roof cone.
 2. Based on 1,244 ft³/bu and 5% compaction below eaves line in cylinder (U.S. bushels).
 3. Based on 770 kg/m³ (48 lb/ft³) and 5% compaction below eaves line in cylinder.

Delivering

TURN-KEY basis solution for
INDUSTRY LEADERS
in 85 countries.



From 1954 until today, Alapala improves with confidence and perseverance in milling technology by producing turn-key flour, semolina, feed mill projects.



HEADQUARTERS & FACTORY
INDUSTRIAL ZONE, 12th STREET NO: 15
PK: 54 / 19040 CORUM - TURKEY
T : +90 364 254 95 60 PBX F: +90 364 254 92 90

SALES & MARKETING
EGS BUSINESS PARK, B3 BLOCK 14th FLOOR
34149 YESILKOY, ISTANBUL - TURKEY
T : +90 212 465 60 40 PBX F: +90 212 465 60 42
info@alapala.com • www.alapala.com



OFFICE
AL-FARABI AVE. 30B, OFFICE # 14
ALMATY, KAZAKHSTAN
T : +7 727 386 81 66
www.alapala.kz

